

This manual contains important warnings and information. READ AND KEEP FOR REFERENCE.

LIQUIDYNAMICS

Hose Reel

Instruction & Parts Manual

Large Capacity Spring Rewind Hose Reel
Model 88402 – 3/4" Hose Capacity
Model 88403 – 1/2" Hose Capacity
Model 88405 – 1" Hose Capacity



P/N 88403-75L



P/N 88405-40L



LIQUIDYNAMICS™

2211 S. Edwards • Wichita, KS 67213
TEL: 316-943-5477 • FAX: 316-943-4760
TOLL FREE: 800-894-3572
E-MAIL: productinfo@liquidynamics.com

WARNING

This symbol indicates a potentially hazardous situation which, if not avoided, could result in death or serious injury.

Introduction:

These hose reels are a practical, safe, reliable and economical way to extend the useful life of hoses, maintain a safe and clean environment and significantly improve Service Technician efficiency. Typical applications are for use with air, water, engine and gear oils, hydraulic and transmission fluids, antifreeze and diesel fuel.

WARNING

Use these reels only for the purpose for which they have been designed. Do not exceed working pressure of reel or hose. Do not use these reels for flammable, explosive or corrosive applications. Do not modify any components and use only original spare parts.

Note: Certain models are supplied with conductive hose and are suitable for use with flammable products such as diesel fuel.

WARNING

If this reel was provided without hose, install hose designed specifically for the purpose for which the reel was designed and follow the original manufacturers specifications for hose requirements. Use only hose rated at or above the working pressure indicated.

Note: Liquidynamics will not accept responsibility for any liability or damages resulting from the use of this product or malfunction associated with hoses not installed by Liquidynamics.

CAUTION

Insure that incoming line pressure does not exceed rated operating pressure of your model hose reel. Refer to technical specifications on page 5 for pressure ratings.

CAUTION

To avoid damage to the reel, control handle or meter, always hold onto hose while it is rewinding.

CAUTION

This symbol indicates a potentially hazardous situation which, if not avoided, may result in injury or damage to equipment.

Before Installation:

1. Make sure mounting surface is sturdy enough to hold the weight of the hose reel and take the stress of use. If wall mounting, check both the inside and outside of wall to make sure no electrical or plumbing lines will interfere with installation.

2. It is recommended to install a supply line shut-off valve just before the connection hose between product supply line and reel, fig. 1. This allows easy maintenance of reel, hose and control valve or meter.

3. Product service labels (fig. 2) are available for ease of installation.

Consult your Liquidynamics catalog or call 800-894-3572 for specific recommendations and part numbers.

4. Flush product supply lines with generous quantities of product in order to remove air, loose dirt, scale, shavings, etc. This will prevent damage to reels, meters and control valves.

5. Determine desired orientation of reel to best fit your specific installation. Reels are shipped with guide arm in position shown in fig. 3.

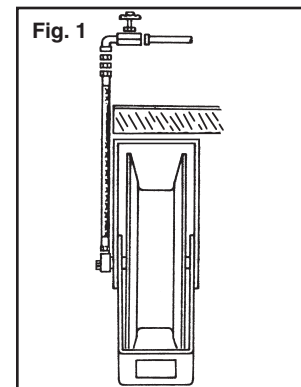
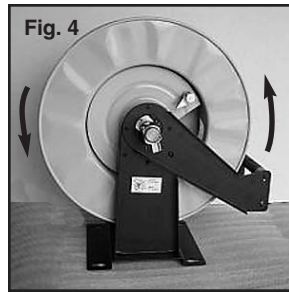

Fig. 2



Note:

Hose spools off from reel in a counterclockwise direction when viewed from swivel side of reel, (fig. 4).



Reels may be mounted on ceiling, wall or tank (floor) as shown in fig. 5a, 5b and 5c. Refer to instructions that follow to reposition guide arm.

Possible Hose Guide Configurations

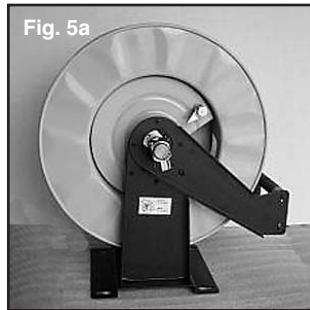

Tank or floor mount, as supplied by Liquidynamics.

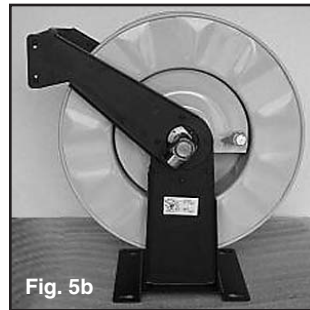

Alternate tank or floor mount.

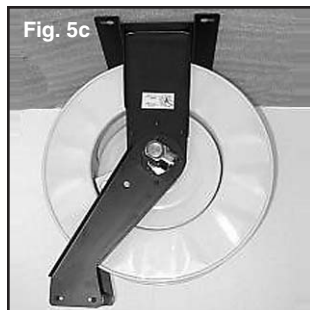

Ceiling mount.

Hose Guide Re-Orientation

Depending on the location of reel installation, it may be necessary or desirable to change the orientation of the hose guide arm, fig. 6. This is easily accomplished without release of spring tension. Possible guide arm orientations are shown in fig. 5, where 5a is the "normal" position as supplied by Liquidynamics.

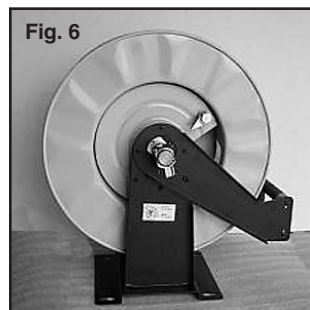
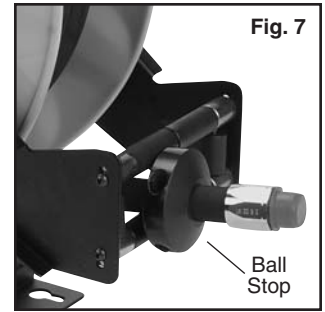

Fig. 5a; used for wall, floor and tank mounting

Fig. 5b; used for wall, floor and tank mounting

Fig. 5c; used for ceiling or wall mount

1. Pull hose from reel until latch key is engaged to prevent hose retraction.
2. Remove ball stop by removing 2 ea. Allen head screws, fig. 7.



Re-position guide arm as shown in fig. 5 as follows:

1. For position 5b
 - a.) Remove 4 ea. 4 mm Allen screws on each side of guide arm, fig. 8.
 - b.) Rotate guide arm to 180° to position shown in fig. 5b.
 - c.) Reinstall 8 ea. 4 mm Allen screws securely.
 - d.) Reinstall ball stop at desired location on hose.
2. For position 5c
 - a.) Remove 4 ea. 4 mm Allen screws on each side of guide arm, fig. 8
 - b.) Rotate guide arm 90° to position shown in fig. 5c.
 - c.) Reinstall 8 ea. 4 mm Allen screws securely.
 - d.) Reinstall ball stop at desired location on hose, Fig 7.

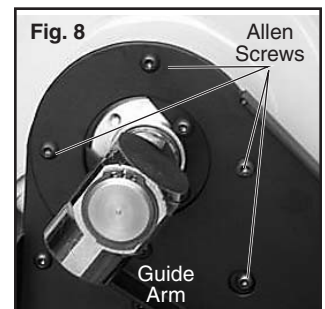

CAUTION

Use apposing wrenches as shown in fig. 9 when attaching the jumper hose to prevent excessive side loading on the swivel joint. Using a single wrench could cause seal or joint damage.

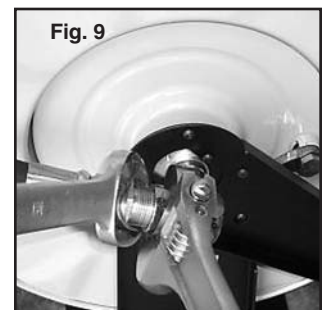

Connecting Jumper Hose

Note: Use an appropriately pressure rated thread sealant such as Loctite 545 on all hose connections to ensure a leak free connection, Fig. 9. Allow thread sealant to cure a minimum of six hours before pressurizing system.

Installing Hose

Note: Use an appropriately pressure rated thread sealant such as Loctite 545 on all hose connections to ensure a leak free connection. Allow thread sealant to cure a minimum of six hours before pressurizing system.

1. Insert hose end with swivel connector through hose guide and attach to hose reel outlet fitting, fig. 10. Tighten swivel connector using open end wrench, fig. 11.

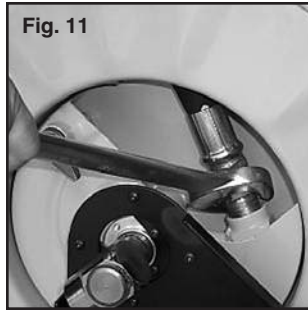
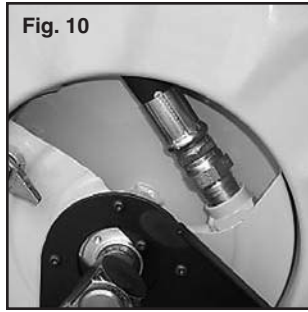

2. Wind hose onto reel by turning hose drum clockwise (as viewed from swivel side) until full length of hose is threaded onto reel.

3. Tension spring by turning hose drum nine full turns counterclockwise for the 88402 and 88403 reels. Turn hose drum five full turns counterclockwise for the 88405 reel.

4. Thread discharge end of hose through hose guide and attach ball stop at desired position, fig. 12.

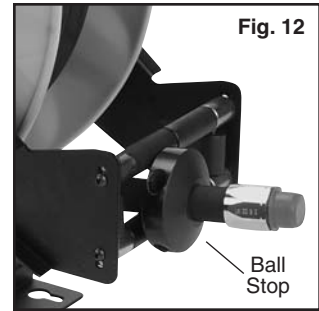

Note: Hose tension may be increased or decreased by using more or less turns as indicated in step #3 above.

CAUTION

Do not exceed 4 turns past point all hose is wrapped onto reel, as this may cause spring damage.

Technical Specifications:

Model	Working Pressure	Hose Dia. ID	Hose Length	Inlet Connection	Outlet Connection	Max Winding Capacity	Connecting Hose Length	Shipping Weight
88402	870 PSI	—	—	3/4" NPTF	3/4" NPTF	3/4 x 50'	—	62 lb
88402-40L	870 PSI	3/4"	40'	3/4" NPTF	3/4" NPTF	—	Not Supplied	78 lb
88402-50L	870 PSI	3/4"	50'	3/4" NPTF	3/4" NPTF	—	Not Supplied	86 lb
88402-40D	150 PSI	3/4"	40'	3/4" NPTF	3/4" NPTF	—	Not Supplied	78 lb
88402-50D	150 PSI	3/4"	50'	3/4" NPTF	3/4" NPTF	—	Not Supplied	86 lb
88403	1,160 PSI	—	—	1/2" NPTF	1/2" NPTF	1/2" x 75'	—	62 lb
88403-50L	1,160 PSI	1/2"	50'	1/2" NPTF	1/2" NPTF	—	2 ft.	70 lb
88403-75L	1,160 PSI	1/2"	75'	1/2" NPTF	1/2" NPTF	—	2 ft.	76 lb
88405	870 PSI	—	—	1" NPTF	1" NPTF	1" x 40'	—	74 lb
88405-30L	870 PSI	1"	30'	1" NPTF	1" NPTF	—	Not Supplied	84 lb
88405-40L	870 PSI	1"	40'	1" NPTF	1" NPTF	—	Not Supplied	96 lb
88405-30D	150 PSI	1"	30'	1" NPTF	1" NPTF	—	Not Supplied	84 lb
88405-40D	150 PSI	1"	40'	1" NPTF	1" NPTF	—	Not Supplied	96 lb

Model 88402 and 88403 Series Reels

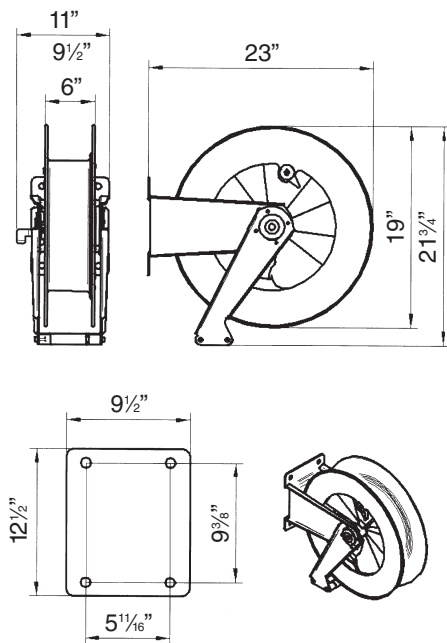

Model 88405 Series Reels

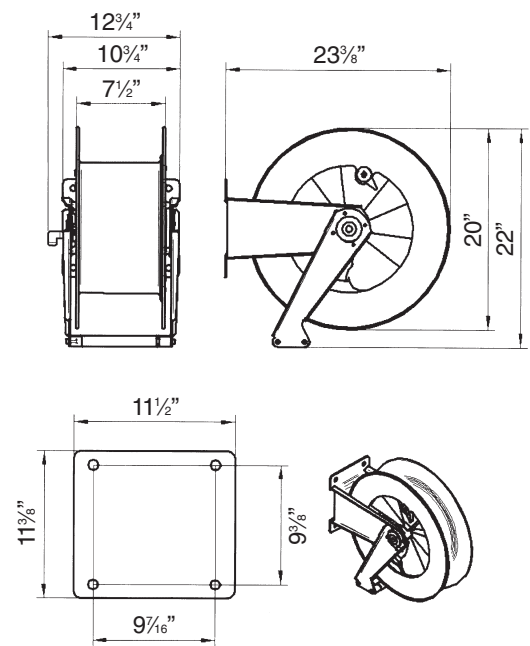

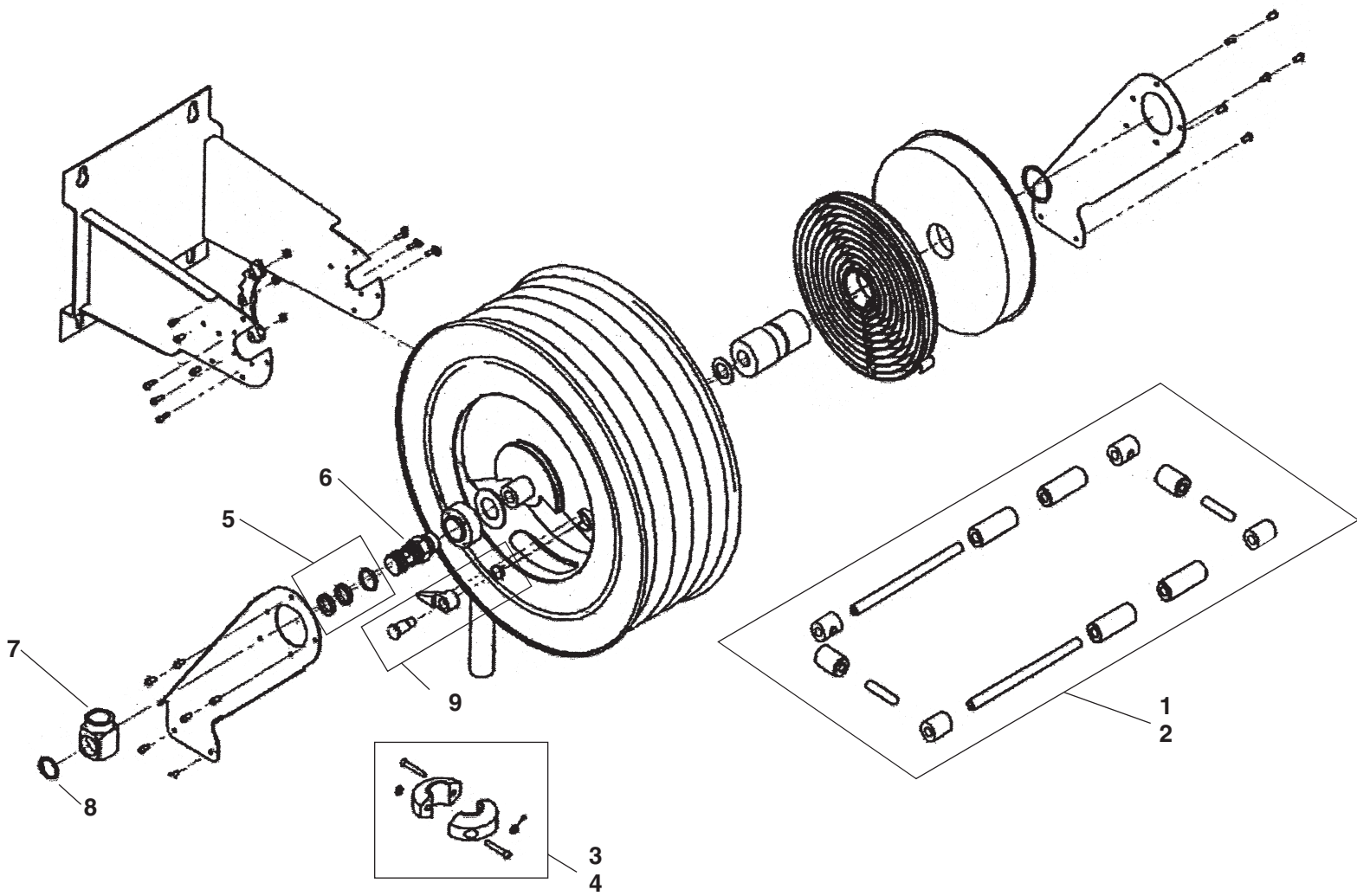

**Exploded Parts Items –
Model 88402, 88403 and 88405 Series:**

- | | | |
|----|--------|--|
| 1. | S45201 | Hose Guide Kit, 88402, 88403 Reels |
| 2. | S45202 | Hose Guide Kit, 88405 Reel |
| 3. | S45203 | Hose Stop, 3/4" Hose |
| 4. | S45204 | Hose Stop, 1" Hose |
| 5. | S45205 | Seal Kit for 88402, 88403 and 88405 Reels |
| 6. | S45206 | Internal Swivel for 88402, 88403 and 88405 Reels |
| 7. | S45207 | 1" Inlet Swivel for 88402, 88403 and 88405 Reels |
| 8. | S45208 | Retaining Ring Clip for 88402, 88403 and 88405 Reels |
| 9. | S45209 | Pawl Kit, Includes pawl, stem and spring (88402,88403 and 88405 Reels) |



LIQUIDDYNAMICS™

2211 S. Edwards • Wichita, KS 67213 / TEL: 316-943-5477 • FAX: 316-943-4760 / TOLL FREE: 800-894-3572
E-MAIL: productinfo@liquidynamics.com / WEBSITE: www.liquidynamics.com