

LIQUIDYNAMICS

1:1, 3:1 and 5:1 RATIO AIR OPERATED OIL PUMPS

Instruction & Parts Manual

This manual covers the following model pumps

P/N 32091
P/N 32095



P/N 20094T
P/N 20073T
P/N 20001T



P/N 21094T
P/N 21073T
P/N 21100T



P/N 21200
P/N 21300



LIQUIDYNAMICS™

2211 S. Edwards • Wichita, KS 67213
TEL: 316-943-5477 • FAX: 316-943-4760
TOLL FREE: 800-894-3572
E-MAIL: productinfo@liquidynamics.com

WARNING

This symbol indicates a potentially hazardous situation which, if not avoided, could result in death or serious injury.

CAUTION

This symbol indicates a potentially hazardous situation which, if not avoided, may result in injury or damage to equipment.

Introduction:

Liquidynamics air operated pumps are used to pump engine oil, gear oil, hydraulic fluid, transmission fluid, 100% antifreeze and similar fluids used in the automobile and truck service industry.

Service and Warranty:

Liquidynamics oil pumps are covered by a limited two year warranty. For parts or service information, call your local distributor or Liquidynamics at 800 894 3572. Please be ready to provide model number and serial number or date of manufacture found on the "Liquidynamics" model number decal on each pump.

Reference the exploded parts drawings found in this manual for specific repair part numbers.

Technical Data:

Part Number (w/o Bung Adapter)	32091	32095	20001T	20073T	20094T	21100T	21073T	21094T	21200	21300
Part Number (w/ Bung Adapter)	32091-S1	32095-S1	20001T-S2	20073T-S2	20094T-S2	21100T-S2	21073T-S2	21094T-S2	21200-S1	21300-S1
Ratio	1:1	1:1	3:1	3:1	3:1	5:1	5:1	5:1	5:1	5:1
Flow Rate @90PSI (GPM)	5	5	5	5	5	5	5	5	8	12
Maximum Air Pressure (PSI)	120	120	120	120	120	120	120	120	120	120
Air Inlet Size	1/4" NPT	1/4" NPT	1/4" NPT	1/4" NPT	1/4" NPT	1/4" NPT	1/4" NPT	1/4" NPT	3/8" NPT	3/8" NPT
Fluid Inlet Size	1" NPT	-	1" NPT	-	-	1" NPT	-	-	1 1/2" NPTF	1 1/2" NPTF
Fluid Outlet Size	1/2" NPTF	1/2" NPTF	1/2" NPTF	1/2" NPTF	1/2" NPTF	1/2" NPTF	1/2" NPTF	1/2" NPTF	3/4" NPTF	3/4" NPTF
Noise	79 db	79 db	79 db	79 db	79 db	79 db	79 db	79 db	79 db	79 db
Air Consumption (cfm)	12	12	12	12	12	12	12	12	18	21
Suction Tube Diameter	1.65"	1.65"	1.65"	1.65"	1.65"	1.65"	1.65"	1.65"	2"	2"
Suction Tube Length	11"	37"	11"	29"	37"	11"	29"	37"	6 1/2"	6 1/2"
Fits Drum Sizes (Gal.)	Universal	55	Universal	16/30	55	Universal	16/30	55	Universal	Universal
Shipping Weight, lbs.	11	14	10	13	15	12	14	16	19	21

Note: For longer pump life and efficiency, we recommend the use of dried air or an air filter. As with any pneumatic equipment, you can expect longer trouble free operation with the use of clean, dry air. The use of an air drier, separator, or minimally an air filter, is advantageous.

Refer to the catalog for Liquidynamics selection of air regulators, separators (filter) and dryers.

General

Liquidynamics oil pumps are supplied completely assembled and ready to use.

The use of an air filter and regulator (figure 1) is recommended to control pumping rate and ensure a clean air supply.



These pumps typically operate in the pressure range of 60-120 PSI. Actual operating air pressure is determined by the type of fluid to be pumped, fluid

temperature, pumping distance, plumbing size, plumbing restrictions and desired flow rate.

CAUTION

Operating air pressure in excess of 120 PSI may cause pump damage and/or reduce pump life.

Installation

1.) Drum Pumps

Models 20073T and 21073T are designed for use with 16 gallon (120 lb) drums, models 20094, 21094 and 32095 are designed for use with 55

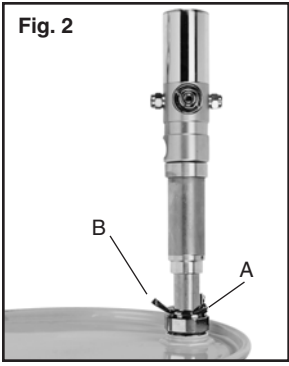

Fig. 2

gallon (420 lb) drums. These pumps may be installed as follows:

- a. Attach the 2" bung adapter, P/N 22157 (item A, fig 2), to the 2" opening at the top of the drum.
- b. Slide the pump into the bung adapter previously installed in step #1 above.

- c. Tighten the wing nut, item B, fig. 2, on bung adapter to secure the pump at the desired height.



Fig. 3

2.) Universal "Stub" Pumps, fig. 3. Stub pumps may be fitted with a 1" NPTM extension pipe and foot valve, P/N 950002 to adapt to most any tank situation (use 1 1/2" in the case of high flow pump P/Ns 21200 and 21300 with 1 1/2" foot valve, P/N 950047). Alternatively, these pumps may be wall mounted with the use of an available wall mounting bracket, P/N 22242 or P/N 22243, fig. 4.

- a. Determine length of extension pipe required to reach bottom of tank by using the extension pipe data chart below:

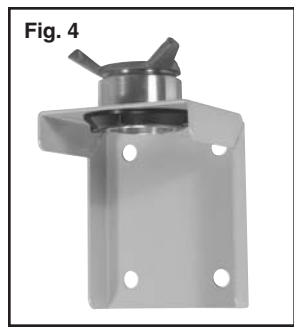
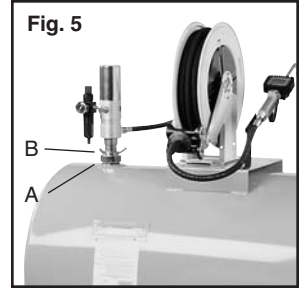

Fig. 4

- b. Attach extension pipe to stub pump taking care to use a thread sealant on both ends of pipe as it is threaded into the pump and foot valve, fig. 3.
- c. Attach bung adapter to 2" tank opening, fig. 5, item A
- d. Slide the assembled pump into bung adapter and tighten wing nut, fig. 5, item B, to secure pump at the desired height.

Fig. 5



- e.) Air Supply: Attach the male portion of a 1/4" (use 3/8" fitting for pump models 21200 and 21300) air quick coupler at the air inlet of the pump or air filter/regulator (item A, fig. 6). This allows a quick and easy method to disconnect the air supply when the pump is being moved or not in use.

Fig. 6



CAUTION

It is important to disconnect or shut off supply air to the pump when left unattended, this prevents the possibility of the pump emptying the fluid container in case of a plumbing leak or catastrophic product line failure.

Extension pipe data chart

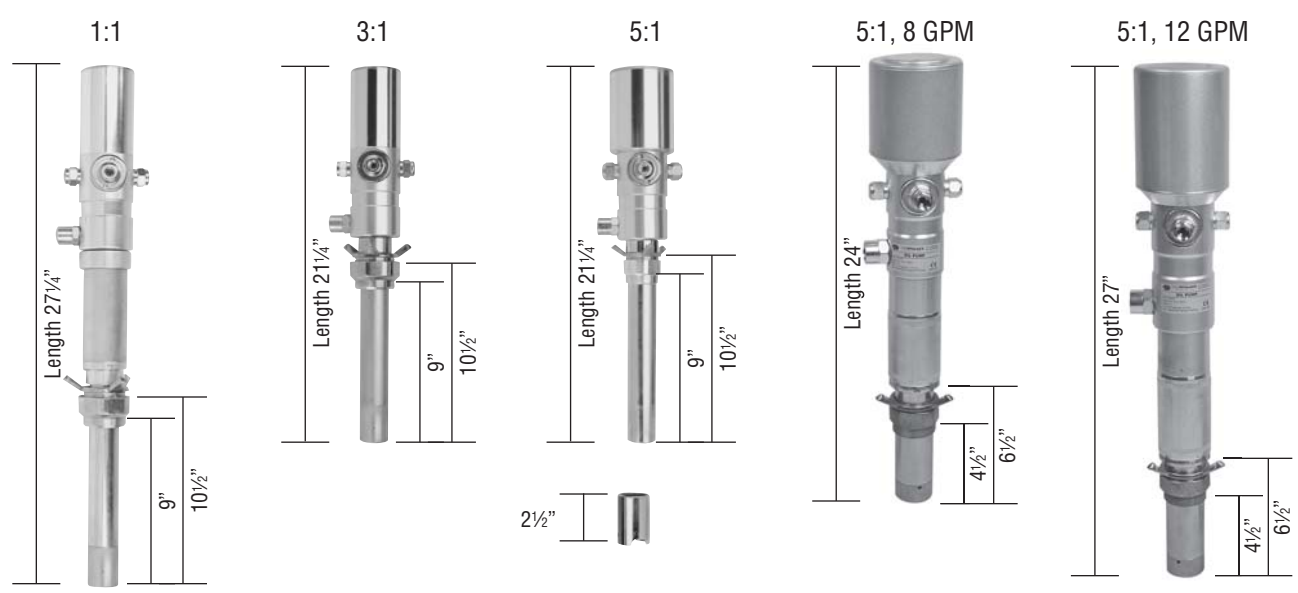

3.) Oil Discharge:

- a. Connect the desired length of 1/2" NPTM hose to the oil discharge port of pump (fig. 7).
- b. Connect an oil control valve or meter to the discharge side of the hose.
- c. The pump is now ready for operation by attaching an air supply to the quick connect fitting installed above.



Operation Notes:

1.) Priming, suction:

In cases where the pump must prime a long distance, such as when the pump is wall mounted, it may be necessary to initially prime the suction hose with fluid to be pumped. Apply air to the pump slowly at a lower than normal operating pressure. Once the pump has primed itself, then adjust air pressure to the desired operating pressure.

2.) Priming, discharge:

Upon initial operation of the pump, it is suggested that a short length of hose be attached to the discharge of the pump and then pump a small quantity of fluid into an appropriate container prior to connecting the pump discharge hose to its normal connection. This ensures that the pump is fully primed.

3.) Foot Valve:

Due to the varying lengths of user installed suction pipes being connected to stub pumps, models 20001T, 21100T, 21200, 21300 and 32091 it is recommended to install a foot valve, (fig. 8) P/N 950002 (P/N 950047 for pump models 21200 and 21300). This helps to maintain pump prime and prevents air from being introduced into the system, which may affect metering accuracy and possibly cause the pump to air lock.

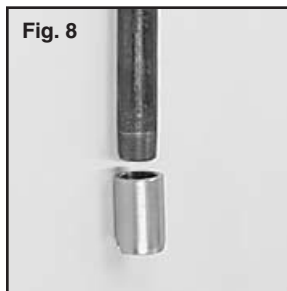

Note: Models 20073T, 20094T, 21073T, 20094T and 32095 come complete with foot valves and are intended for use in 16 and 55 gallon drums. It is not necessary to install any additional foot valves in

this case.

4.) Relief Valve:

Thermal expansion of fluid is an industry wide problem that may cause leaky pipe joints, swivel leaks on reels, meter and control handle leaks, blistered hoses and component failures, to mention just a few "common" problems.

Thermal expansion results from fluid expanding due to temperature increases. This can occur most any time of the year but is most prevalent in the summer and winter. In the summer, thermal heating by the sun may cause temperatures near the ceiling, where oil lines are typically located, to reach 120 to 140 deg F or higher. In the winter, heating systems cause ceiling temperatures to be significantly higher than temperatures at ground level, where oil storage tanks are located. In a closed system, there is an approximate 44 PSI increase in pressure for every degree F rise in fluid temperature.

Thermal expansion valve kits, (fig. 9) P/N 540025 or 540037 are recommended for use in installations where thermal expansion may be a problem. These kits will prevent over pressurization by relieving excess pressure back to the supply tank.

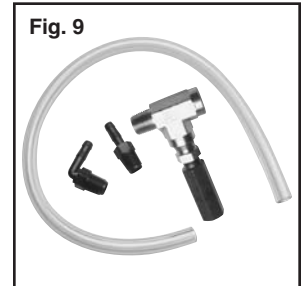

Please feel free to contact Liquidynamics at 800-894-3572 if you have any questions regarding applications or installation.

Maintenance

- 1.) On a day to day basis these pumps are maintenance free. For your future reference regarding replacement of components, please refer to the appropriate exploded parts diagram.
- 2.) To maintain system integrity it is recommended to periodically inspect all system components for evidence of excessive wear or leaks. Particular attention should be given to wear items such as hoses and swivel joints.
- 3.) Please contact Liquidynamics at 800 894 3572, or your local distributor for repair components and kits.

1:1 Ratio Pumps

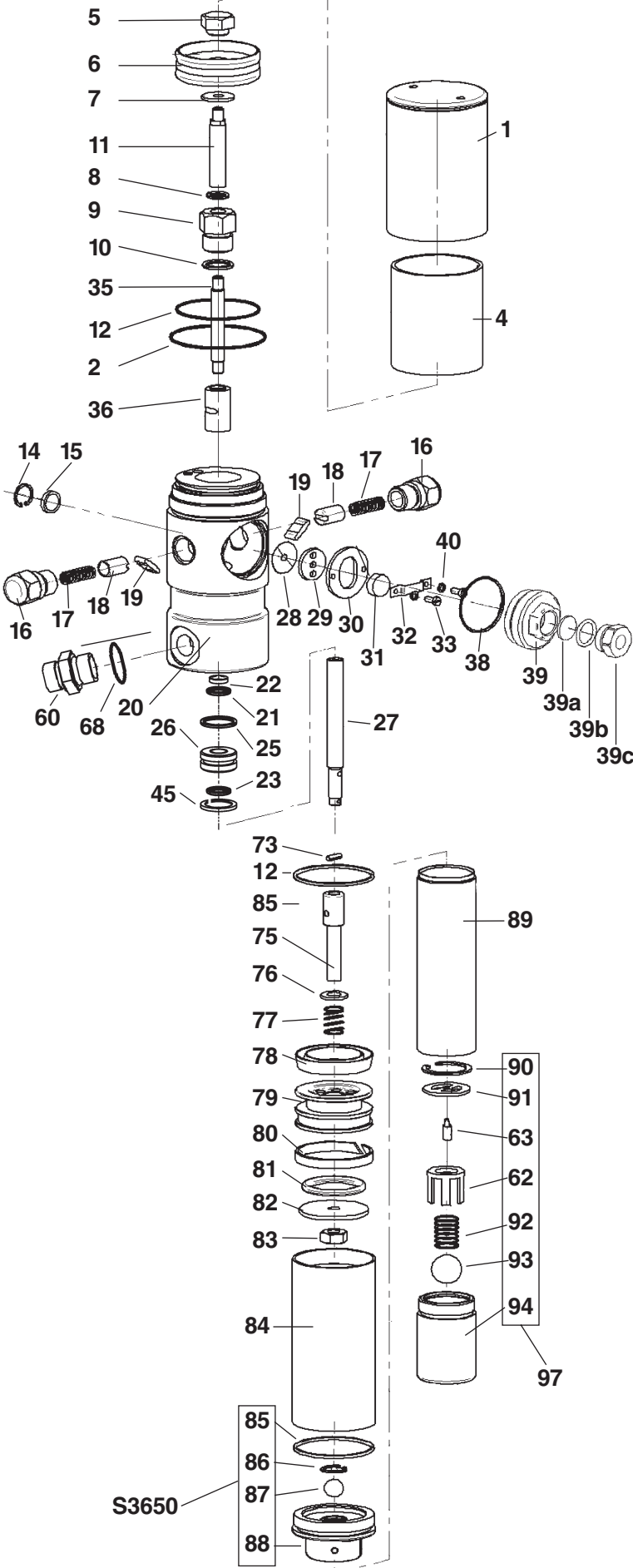

Exploded Parts Items – Models 32091 and 32095

Repair Kits:

P/N S3640	Air Motor Seal & Slide Kit 2, 6, 8, 10, 12, 21, 22, 23, 25, 28, 29, 31, 32, 33, 38, 40
P/N S3640-20	Same as S3640 but for use with pumps built prior to S/N D04.
P/N S3642	Shuttle Kit 17, 18, 19 (2 ea.)
P/N S3649	Wet-side Repair Kit 73, 77, 78, 80, 81, 85, 86, 87
P/N S3650	Ball Check Kit 85, 86, 87, 88

Individual Repair Components:

1	P/N S3612-03	Cap, cylinder, outer
4	P/N S3612-04	Cylinder, Inner
5	P/N S3612-05	Nut, Cap
7	P/N S3612-07	Washer
9	P/N S3612-09	Connector
11	P/N S3612-11	Rod, Upper
14	P/N S3612-14	Retainer, Muffler
15	P/N S3612-15	Muffler
16	P/N S3612-16	Screw, Cap
20	P/N S3612-20	Body, Air Motor
26	P/N S3612-26	Seal, Guide
27	P/N S3612-27	Shaft
30	P/N S3612-30	Guide, Slide
35	P/N S3612-35	Rod, Lower
36	P/N S3612-36	Body, Toggle
45	P/N S3612-45	Retaining Clip
39	P/N S3612-39a	Cap screw, air inlet
39a	P/N S3612-13a	Filter, air
39b	P/N S3612-13b	O Ring
39c	P/N S3612-23c	Adapter, 1/4"
60	P/N S3612-60	Fitting, Discharge, 1/2" NPTF
68	P/N S3612-68	Washer, Metal
72	P/N S3612-72	Fitting, Upper
75	P/N S3612-75	Shaft (for 32091)
75a	P/N S3612-75a	Shaft (for 32095)
79	P/N S3612-79	Piston
82	P/N S3612-82	Washer
83	P/N S3612-83	Nut
84	P/N S3612-84	Cylinder, Upper
88	P/N S3612-88	Fitting, Lower
89	P/N S3612-89	Cylinder (for 32091)
89a	P/N S3612-89a	Cylinder (for 32095)
97	P/N S3652	Inlet Ball Check Kit

3:1 Ratio Pumps

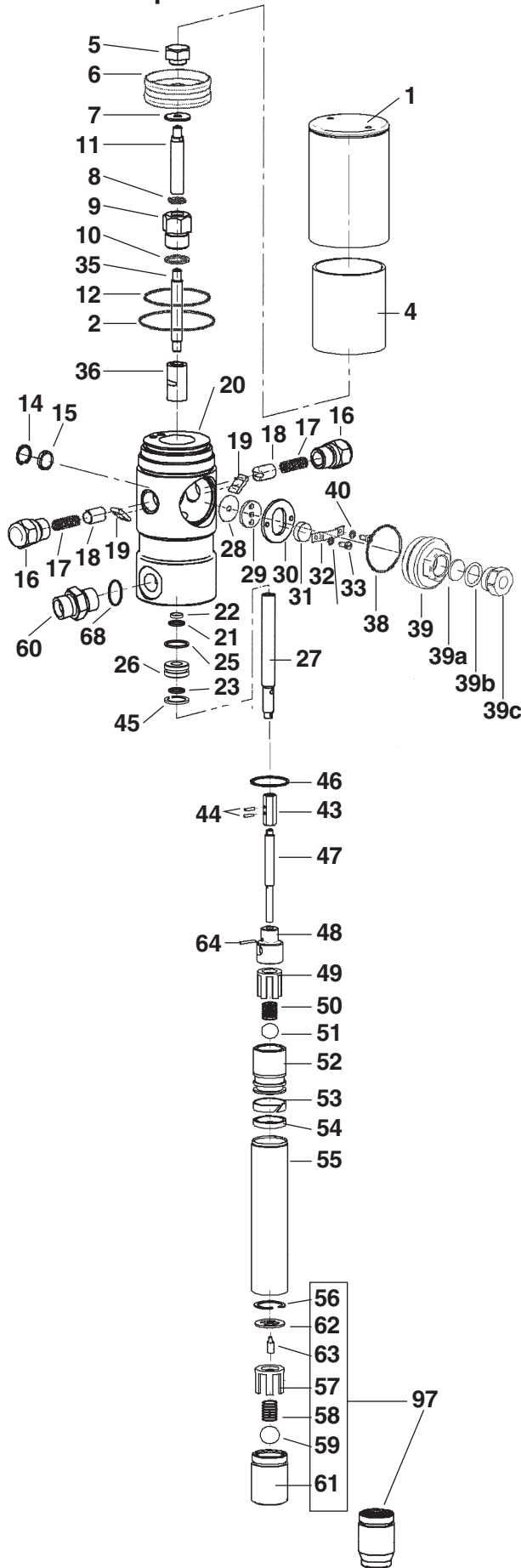

Exploded Parts Items – Models 20001T, 20073T and 20094T:

Repair Kits:

P/N S3640	Air Motor Seal & Slide Kit 2, 6, 8, 10, 12, 21, 22, 25, 28, 29, 31, 32, 33, 38, 40
P/N S3640-20	Same as S3640 but for use with pumps built prior to S/N D04.
P/N S3642	Shuttle Kit 17, 18, 19 (2 ea.)
P/N S3643	Wet-side Repair Kit 44, 46, 50, 53, 54, 64,

Individual Repair Components:

1	P/N S3612-03	Cap, cylinder, outer
4	P/N S3612-04	Cylinder, Inner
5	P/N S3612-05	Nut, Cap
7	P/N S3612-07	Washer
9	P/N S3612-09	Connector
11	P/N S3612-11	Rod, Upper
14	P/N S3612-14	Retainer, Muffer
15	P/N S3612-15	Muffer
16	P/N S3612-16	Screw, Cap
20	P/N S3612-20	Body, Air Motor
26	P/N S3612-26	Seal, Guide
27	P/N S3612-27	Shaft
30	P/N S3612-30	Guide, Slide
35	P/N S3612-35	Rod, Lower
36	P/N S3612-36	Body, Toggle
39	P/N S3612-39a	Cap screw, air inlet
39a	P/N S3612-13a	Filter, air
39b	P/N S3612-13b	O Ring
39c	P/N S3612-23c	Adapter, 1/4"
43	P/N S3612-43	Coupler
45	P/N S3612-45	Retaining Clip
47	P/N S3612-47	Shaft (for 20001T)
47a	P/N S3612-47a	Shaft (for 20073T)
47b	P/N S3612-47b	Shaft (for 20094T)
48	P/N S3612-48	Fitting, Coupler
49	P/N S3612-49	Cage
51	P/N S3612-51	Ball Check
52	P/N S3612-52	Fitting, Tube, Upper
55	P/N S3612-55	Tube (for 20001)
55a	P/N S3612-55a	Tube (for 20073)
55b	P/N S3612-55b	Tube (for 20094)
60	P/N S3612-60	Fitting, Discharge 1/2" NPTF
68	P/N S3612-68	Washer, Metal
97	P/N S3648	Foot Valve Assembly

5:1 Ratio Pumps

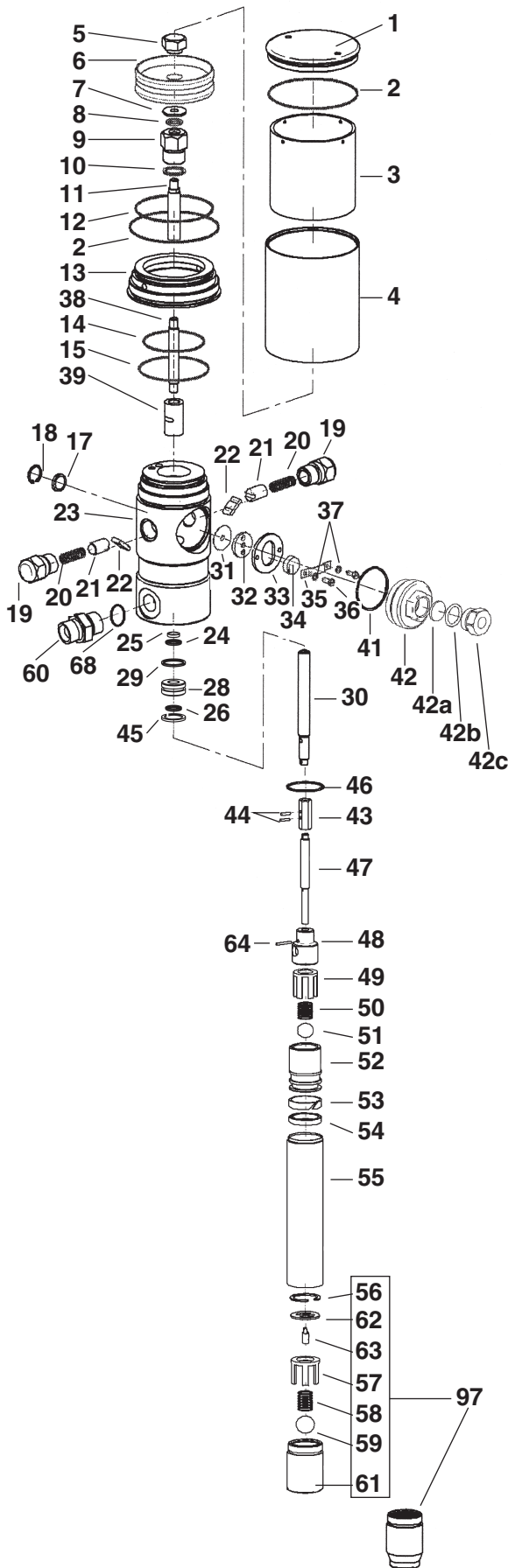

Exploded Parts Items – Models 21100T, 21073T and 21094T:

Repair Kits:

P/N S3644	Air Motor Seal & Slide Kit 2, 6, 8, 10, 12, 14, 15, 24, 25, 26, 29, 31, 32, 34, 35, 36, 37, 41
P/N S3644-20	Same as S3644 but for use with pumps built prior to S/N D04.
P/N S3642	Shuttle Kit 20, 21, 22 (2 ea.)
P/N S3643	Wet-side Repair Kit 44, 46, 50, 53, 54, 64

Individual Repair Components:

1	P/N S3620-01	Cap
3	P/N S3620-03	Cylinder, Inner
4	P/N S3620-04	Cylinder, Outer
5	P/N S3612-05	Nut, Cap
7	P/N S3612-07	Washer
9	P/N S3612-09	Connector
11	P/N S3612-11	Rod, Upper
13	P/N S3620-13	Adapter, Body 5:1
17	P/N S3612-15	Muffler
18	P/N S3612-14	Retainer, Muffler
19	P/N S3612-16	Screw, Cap
23	P/N S3612-20	Body, Air Motor
28	P/N S3612-26	Seal, Guide
30	P/N S3612-27	Shaft
33	P/N S3612-30	Guide, Slide
38	P/N S3612-35	Rod, Lower
39	P/N S3612-36	Body, Toggle
42	P/N S3612-39a	Cap Screw, Air Inlet
42a	P/N S3612-13a	Filter, Air
42b	P/N S3612-13b	O Ring
42c	P/N S3612-23c	Adapter, 1/4"
43	P/N S3612-43	Coupler
45	P/N S3612-45	Retaining Clip
47	P/N S3612-47	Shaft (for 21100)
47a	P/N S3612-47a	Shaft (for 21073)
47b	P/N S3612-47b	Shaft (for 21094)
48	P/N S3613-48	Fitting, Coupler
49	P/N S3613-49	Cage, spring
51	P/N S3613-51	Ball Check
52	P/N S3613-52	Fitting, Tube, Upper
55	P/N S3612-55	Tube (for 21100T)
55a	P/N S3612-55a	Tube (for 21073T)
55b	P/N S3612-55b	Tube (for 21094T)
60	P/N S3612-60	Fitting, Discharge 1/2" NPTF
68	P/N S3612-68	Washer, Metal
97	P/N S3648	Foot Valve Assembly

5:1 Ratio Pumps – 8 GPM

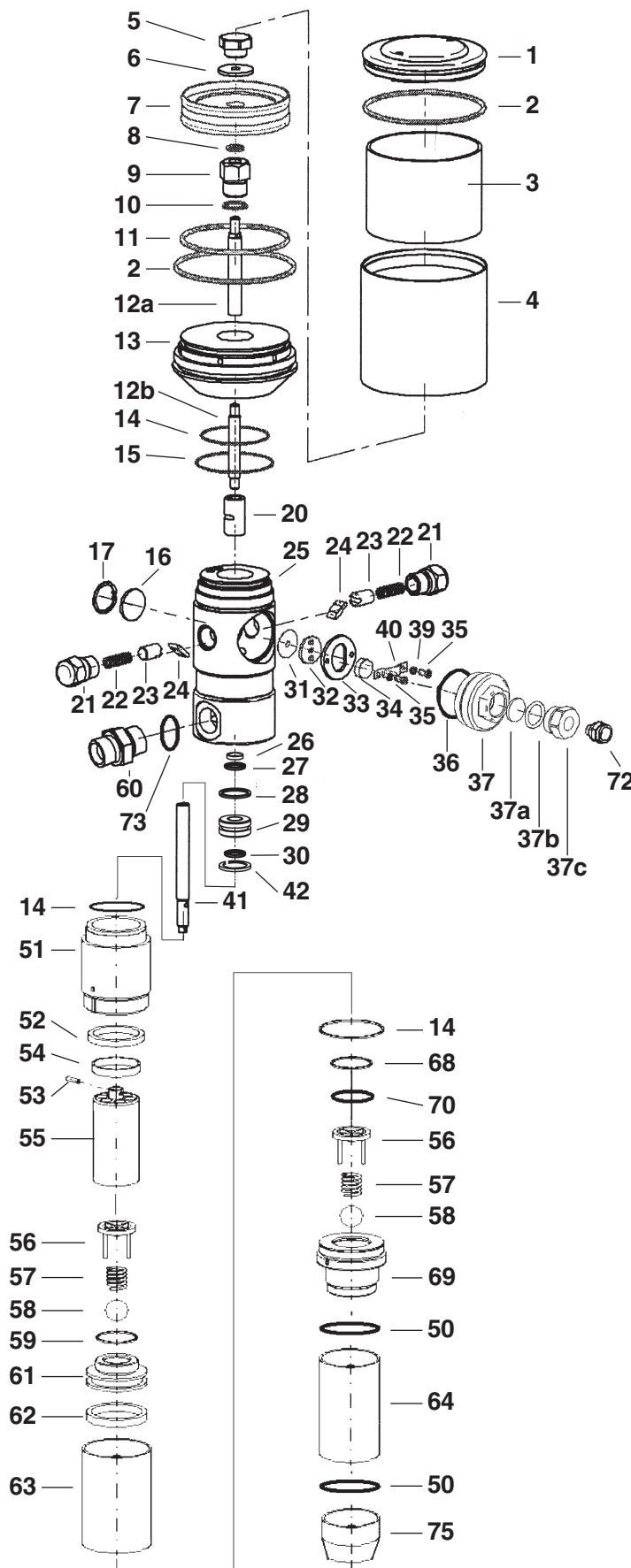

Exploded Parts Items – Models 21200:

Repair Kits:

P/N S3664	Air Motor Seal & Slide Kit 2, 7, 8, 10, 11, 14, 15, 26, 27, 28, 30, 31, 32, 34, 35, 36, 39, 40
P/N S3642	Shuttle Kit 22, 23, 24 (2 ea.)
P/N S3661	Wet-side Repair Kit 14, 50, 52, 53, 54, 56, 57, 59, 62, 68, 70,

Individual Repair Components:

1	P/N S3665-01	Cap
3	P/N S3665-03	Cylinder, Inner
4	P/N S3665-04	Cylinder, Outer
5	P/N S3612-05	Nut, Cap
6	P/N S3612-07	Washer
9	P/N S3612-09	Connector
12a	P/N S3665-12a	Rod, Upper
12b	P/N S3665-12b	Rod, Lower
13	P/N S3665-13	Adapter, Body 5:1
16	P/N S3665-16	Muffler, Disc
17	P/N S3665-17	Retainer, Muffler
20	P/N S3612-36	Toggle
21	P/N S3612-16	Screw, Cap
25	P/N S3665-25	Body, Air Motor
29	P/N S3612-26	Seal, Guide
33	P/N S3612-30	Guide, Slide
37	P/N S3612-39a	Cap Screw, Air Inlet
37a	P/N S3612-13a	Filter, Air
37b	P/N S3612-13b	O Ring
37c	P/N S3612-23c	Air Inlet, 1/4"
41	P/N S3665-41	Shaft, Air Motor
42	P/N S3612-45	Retaining Clip
51	P/N S3671-51	Cylinder, Extension, 8 GPM
55	P/N S3671-55	Piston, 8 GPM
58	P/N S3670-58	Ball Check
60	P/N S3665-60	Fitting, Discharge 3/4" NPTF
61	P/N S3670-61	Ball Check, Seat
63	P/N S3671-63	Cylinder, Pumping, 8 GPM
64	P/N S3670-64	Tube, Suction, Stub
69	P/N S3670-69	Fitting, Adapter
72	P/N S3612-13d	Adapter, 3/8" Air Inlet
73	P/N S3670-73	Washer, Metal
75	P/N S3670-75	Fitting, Inlet, 1/2" NPTF

5:1 Ratio Pump – 12 GPM

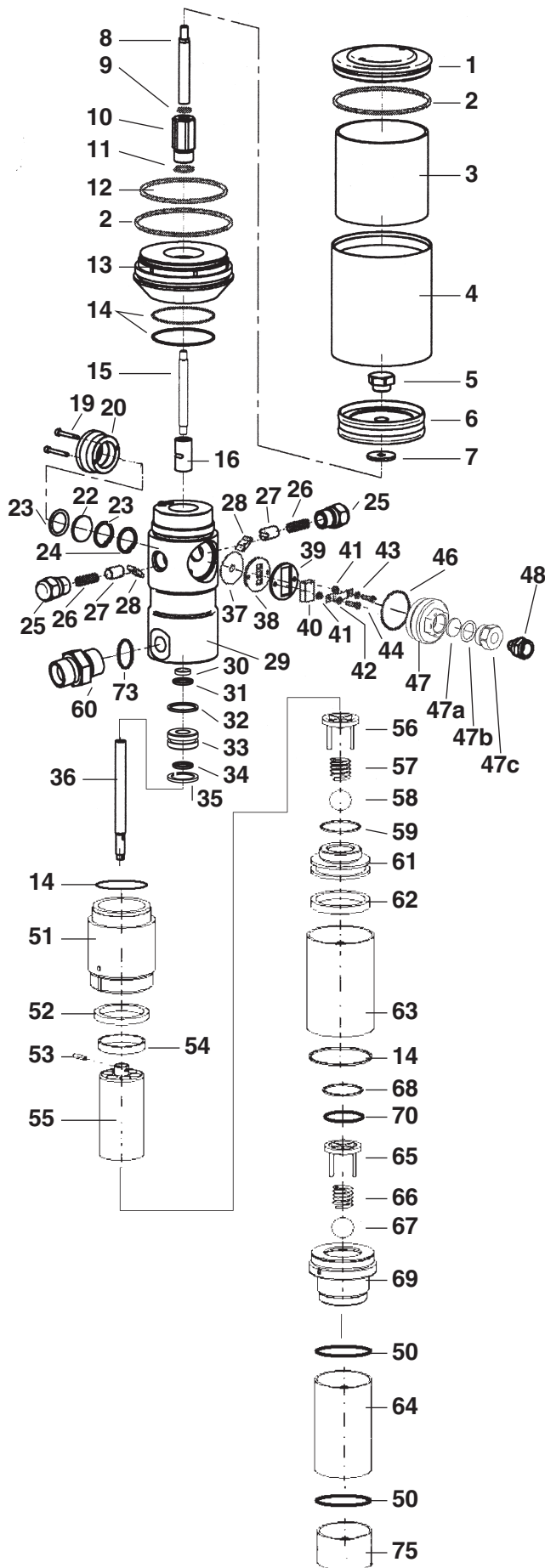

Exploded Parts Items – Models 21300:

Repair Kits:

P/N S3663	Air Motor Seal & Slide Kit 2, 6, 9, 11, 12, 14, 30, 31, 32, 34, 37, 38, 40, 41, 42, 43, 44, 46
P/N S3642	Shuttle Kit 26, 27, 28 (2 ea.)
P/N S3662	Wet-side Repair Kit 14, 50, 52, 53, 54, 56, 57, 59, 62, 65, 66, 68, 70

Individual Repair Components:

1	P/N S3665-01	Cap
3	P/N S3668-03	Cylinder, Inner
4	P/N S3668-04	Cylinder, Outer
5	P/N S3612-05	Nut, Cap
7	P/N S3612-07	Washer
8	P/N S3668-08	Rod, Upper
10	P/N S3668-10	Connector
13	P/N S3665-13	Adapter, Body 5:1
15	P/N S3668-15	Rod, Lower
16	P/N S3612-36	Toggle
19	P/N S3668-19	Screw, Retainer
20	P/N S3668-20	Housing, Muffler
22	P/N S3668-22	Spacer, 'O' Ring
23	P/N S3668-21	Muffler, Bronz
24	P/N S3668-24	Retainer, 'C' Clip
25	P/N S3612-16	Screw, Cap
29	P/N S3665-29	Body, Air Motor
33	P/N S3612-26	Seal Guide
35	P/N S3612-45	Retaining Clip
36	P/N S3665-41	Shaft, Air Motor
39	P/N S3668-39	Guide, Slide
47	P/N S3612-39a	Cap Screw, Air Inlet
47a	P/N S3612-13a	Filter, Air
47b	P/N S3612-13b	O Ring
47c	P/N S3612-13c	Air Inlet, 1/4"
48	P/N S3612-13d	Adapter, 3/8" Air Inlet
51	P/N S3670-51	Cylinder, Extension, 12 GPM
55	P/N S3670-55	Piston, 12 GPM
58	P/N S3670-58	Ball Check
60	P/N S3665-60	Fitting, Discharge 3/4" NPTF
61	P/N S3670-61	Ball Check, Seat
63	P/N S3671-63	Cylinder, Pumping, 12 GPM
64	P/N S3670-64	Tube, Suction, Stub
69	P/N S3670-69	Fitting, Adapter
73	P/N S3670-73	Seal, copper, Discharge
75	P/N S3670-60	Fitting, Inlet 1/2" NPTF



LIQUIDDYNAMICS™

2211 S. Edwards • Wichita, KS 67213 / TEL: 316-943-5477 • FAX: 316-943-4760 / TOLL FREE: 800-894-3572
E-MAIL: productinfo@liquidynamics.com / WEBSITE: www.liquidynamics.com